

Industrial machinery and heavy equipment

Sparkonix

Industrial machinery manufacturer uses Teamcenter Rapid Start to reduce design time by 25 percent

Products

Teamcenter, Solid Edge

Business challenges

Manage growing amount of CAD data more effectively

Speed product development

Facilitate re-use of design data

Improve control of access to data

Keys to success

Use Teamcenter Rapid Start to get PDM up and running quickly

Automate data management process

Select PDM solution that requires minimal IT expertise to support and maintain

Engage strong support of software partner and GTAC

Results

Reduced design time by 25 percent

Enabled designers to spend less time storing, searching and retrieving data

Sparkonix implements PDM quickly to help designers significantly decrease time spent searching for storing and retrieving data

Corralling data

Sparkonix India Private Limited (Sparkonix), which was established in 1968, is a leading manufacturer and exporter of electrical discharge machining (EDM) equipment. The company also produces special-purpose EDM drill machines and metal arc disintegrators, which are used to remove broken taps and drills. Furthermore, the company engineers a range of innovative solutions in steel rebar branding and handling, and construction technologies.

Sparkonix machines typically include hundreds of parts, from fabricated and machined parts to castings, sheet metal, electronics and electrical items mounted directly on mechanical assemblies. Its market is the die and mold industry and special purpose machine (SPM) and special purpose drill (SPD) EDM operators.

Sparkonix uses Solid Edge® software from product lifecycle management (PLM) specialist Siemens PLM Software for computer-aided design (CAD). However, the company was finding it difficult to manage a rapidly expanding amount of design data.

"The amount of CAD data was growing and we needed to manage it better so that no

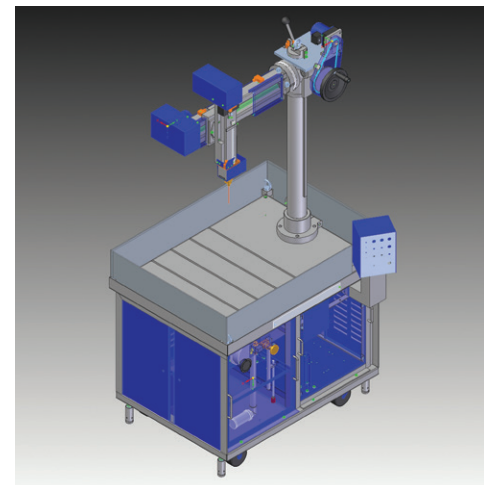

unnecessary duplicates would be created," says Anand Atole, assistant manager of Design at Sparkonix. "Being able to re-use design data to speed up work was a priority. Also, the number of users accessing data was increasing and we required control of user workflow, so we needed revision management."

Speeding up the process

Sparkonix is in a highly competitive market, so the company needed to come up with new concepts and designs. The company was intent on improving its existing products and processes without compromising quality. Achieving this while keeping costs in mind was a big challenge, as was meeting deadlines for deliveries of customer orders and providing updates to marketing on changes to designs.

Results continued

Reduced inventory by standardizing on a limited number of part sizes

Streamlined and kept better track of process workflows

“The amount of CAD data was growing and we needed to manage it better so that no unnecessary duplicates would be created. Being able to re-use design data to speed up work was a priority. Also, the number of users accessing data was increasing and we required control of user workflow, so we needed revision management.”

Anand Atole
Asst. Manager of Design
Sparkonix

With these challenges delaying the design-to-delivery process, the company knew it needed a solution that would enable it to move significantly faster, especially with customer demand continually increasing.

Sparkonix previously had a central location for data, but it could not be easily searched. Equally frustrating, Sparkonix was unable to re-use the data. In addition, it was hard to avoid creating duplicate data, and anybody could access it. What Sparkonix wanted was total control of its design data, with ease of access, the ability to readily re-use the data and strong security.

Streamlining design data

Sparkonix found the answer to its information management challenges in Siemens PLM Software’s Teamcenter® software Rapid Start configuration.

“By choosing Teamcenter Rapid Start, we have a central repository for design data with strong management capabilities,”

says Anand. “We can search our database for required information to use and re-use parts and assemblies.

“Now we are able to efficiently manage product revisions. We can control the access rights to data based on user type, and share updated data easily and immediately. As a result, we have moved to more controlled paperless operations for the design department. Earlier, we had to do manual paperwork to maintain data that is now being handled by our PDM software,” says Anand. Currently, Sparkonix is using Teamcenter Rapid Start to provide design data to purchasing, sales and support. People can view documents and designs in Teamcenter Rapid Start, because the embedded visualization capabilities present designs in CAD-neutral JT format for viewing and markup. Stakeholders don’t need access to CAD applications to collaborate and get the information they need to make the right product decisions.

“Ultimately, Teamcenter Rapid Start has enabled us to streamline design data and make it available to all for re-use, from design to sales and support. Designers can now concentrate on design rather than on storing, searching for and retrieving data. We have reduced design time by 25 percent.”

Getting into production quickly

Sparkonix opted for Teamcenter Rapid Start because it wanted to get up and running quickly and immediately apply PDM best practices for data and process management. What’s more, the company wanted an affordable option suited to its small business profile.

Teamcenter Rapid Start provided the PDM capabilities Sparkonix needed at a compelling price, while giving the company the option to grow into a full-scale PLM implementation at any time. Because Teamcenter Rapid Start is a preconfiguration of Teamcenter, Sparkonix can extend its implementation to PLM while retaining the preconfigured menu options and processes for PDM.

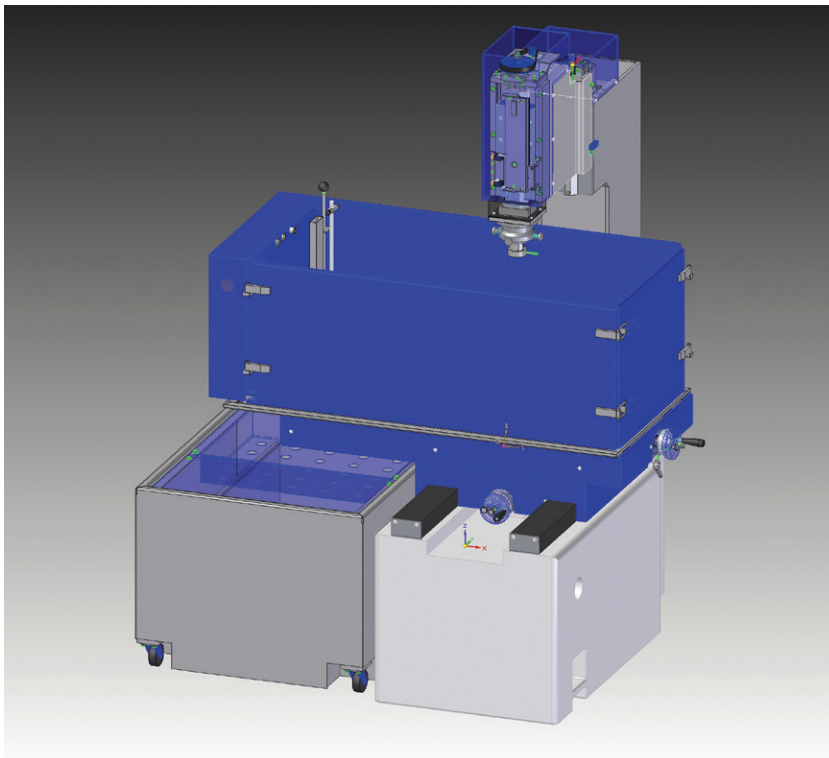

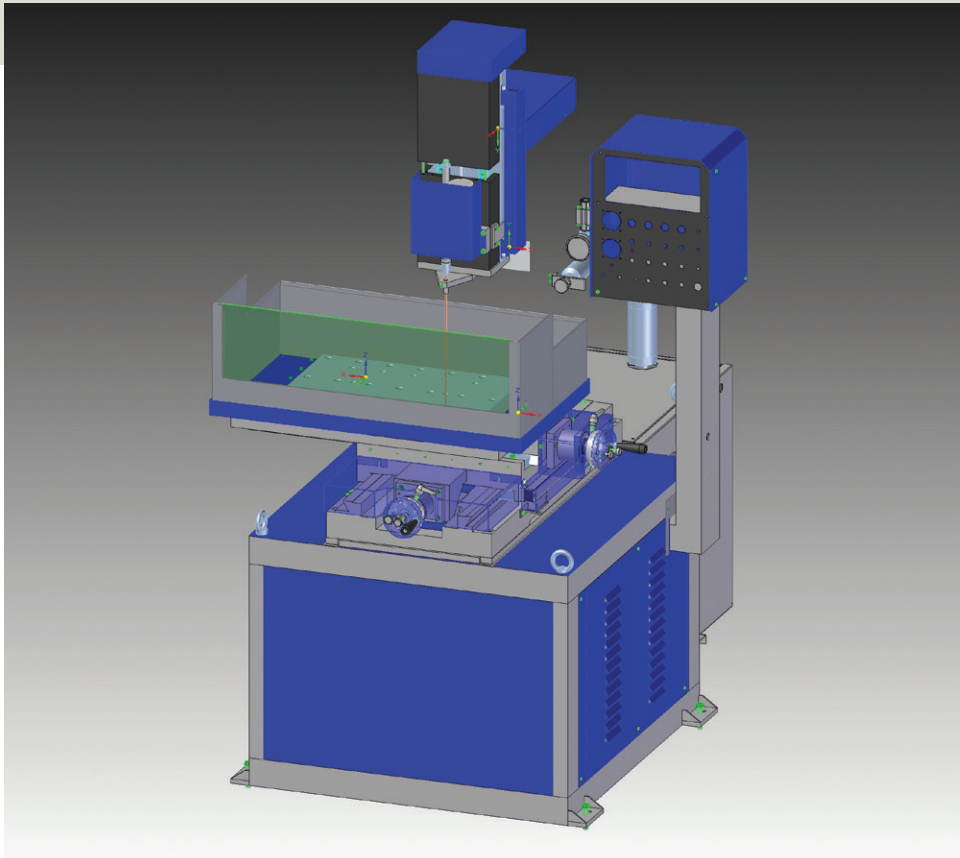

“Now we are able to efficiently manage product revisions. We can control the access rights to data based on user type, and share updated data easily and immediately. As a result, we moved to more controlled paperless operations for the design department.”

Anand Atole
Asst. Manager of Design
Sparkonix

“Ultimately, Teamcenter Rapid Start has enabled us to streamline design data and make it available to all for re-use, from design to sales and support.”

Anand Atole
Asst. Manager of Design
Sparkonix

Following the standard PDM deployment methodology and best practices, Sparkonix implemented Teamcenter Rapid Start in just four weeks, taking two days to train its users. The company can easily upgrade with each future release, noting that it takes minimal information technology (IT) expertise to support and maintain the system.

Trimming inventory

Among a long list of examples that demonstrates the software’s advantages, the company is using Teamcenter Rapid Start for the pipes its uses to connect pumps and filters. “With Teamcenter Rapid Start, we are able to get an idea about the different sizes of pipes that are being used,”

Solutions/Services

Teamcenter Rapid Start
www.siemens.com/plm/teamcenter/rapidstart

Solid Edge
www.siemens.com/solidedge

Customer's primary business

Sparkonix, established in 1968, is a leading manufacturer and exporter of EDM and metal arc disintegrators. In addition, the company delivers a range of innovative solutions in steel rebar branding and handling as well as construction technologies.
www.sparkonix.com

Customer location

Pune, Maharashtra
India

Partner

Pentacle Technosys
Pune, India

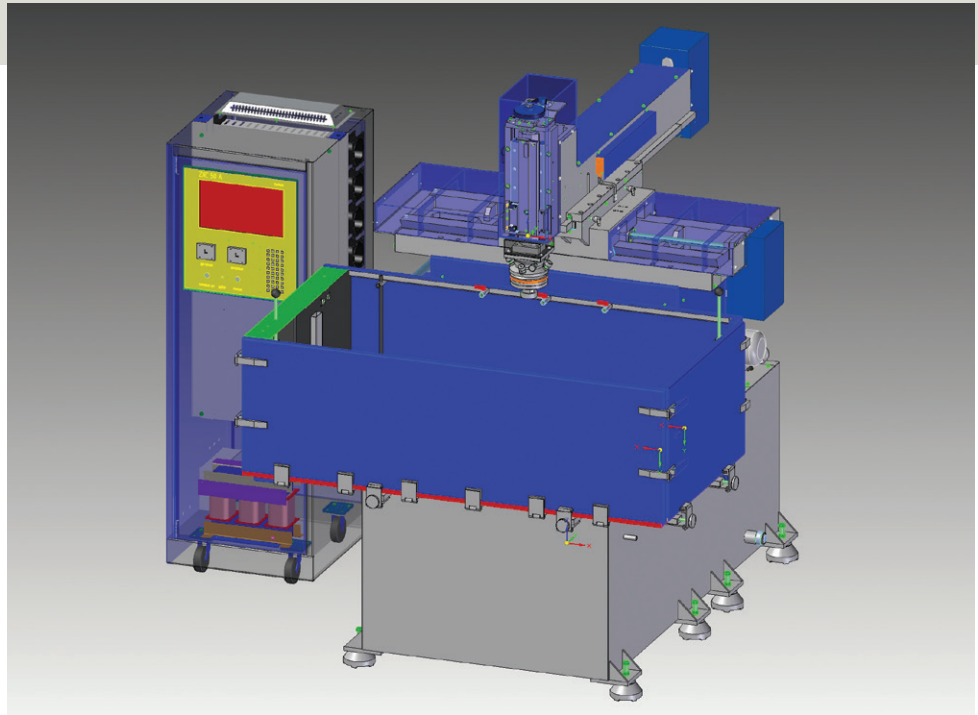

says Anand. "Then we can decide to limit variations of pipe lengths and settled on some common sizes, so now we avoid maintaining excess inventory."

Using the preconfigured processes in Rapid Start – such as design review, supplier design exchange and change management workflow – Sparkonix can streamline and better track project status.

Utilizing support

From the start, Sparkonix had the support it needed to succeed. "Our software partner helped at each stage of the implementation process to get us working quickly and effectively," says Anand. He notes, "Siemens PLM Software's Global Technical Access Center (GTAC) is always there to help us out with any matter in which we desire assistance."

“Designers can now concentrate on design rather than on storing, searching for and retrieving data. We have reduced design time by 25 percent.”

Anand Atole
Asst. Manager of Design
Sparkonix

Siemens PLM Software

Americas +1 314 264 8499
Europe +44 (0) 1276 413200
Asia-Pacific +852 2230 3308

www.siemens.com/plm

© 2015 Siemens Product Lifecycle Management Software Inc. Siemens and the Siemens logo are registered trademarks of Siemens AG. D-Cubed, Femap, Fibersim, Geolus, GO PLM, I-deas, Insight, JT, NX, Parasolid, Solid Edge, Syncrofit, Teamcenter and Tecnomatix are trademarks or registered trademarks of Siemens Product Lifecycle Management Software Inc. or its subsidiaries in the United States and in other countries. Other logos, trademarks, registered trademarks or service marks belong to their respective holders.

52012-Z7 10/15 H