

Trimble Earthworks

Grade Control Platform for Compact Machines



Small Machine, BIG Potential

Leave a finished grade the first time, every time.

Ask for the next generation of machine control. From the company that invented machine control.

The **Trimble® Earthworks Grade Control Platform for Compact Machines** helps operators of all levels leave a quality surface in their tracks. This latest release in the Trimble Earthworks family is more than future forward. It's fast forward. The next generation system with a familiar Android™ UI, and friendly 10-inch touch screen cuts learning curve, improves operator capabilities, and gives you a first-pass finish that's second to none.

Now available in a subscription model with flexible terms to modernize your equipment with no large upfront cost.

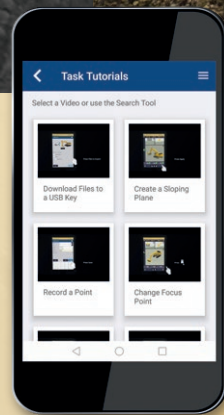

Download the **Trimble Earthworks Assistant** app to easily access consolidated Trimble Earthworks learning material and documentation, allowing for a shorter learning curve and less downtime.

The Trimble Earthworks Assistant app makes it easy to learn and troubleshoot using an Android cell phone, even from remote sites.

Available on the Google Play Store



INTUITIVE SOFTWARE, RUGGED HARDWARE

The Trimble Earthworks Software runs on the 10-inch (25.4 cm) Trimble TD520 display or the 7-inch (17.8 cm) Trimble TD510 display. Colorful graphics, natural interactions and gestures, and self-discovery features make Trimble Earthworks intuitive and easy to learn. Each operator can personalize the interface to match their workflow and a variety of configurable views make it easier to see the right perspective for maximum productivity.

To ensure everyone is operating from the latest design, transfer data files to or from the office wirelessly and automatically using Trimble WorksManager, mobile-friendly software that easily manages data and technology assets across project sites.

OPTIONS TO GET THE JOB DONE RIGHT

Trimble Earthworks for compact machines gives you a variety of sensor options to meet the needs of your next job.

Offering GNSS based systems, as well as universal total station and laser options, we have what you need whether flexibility or the ultimate level of precision is your goal.

SOLUTIONS MADE FOR YOUR SMALL MACHINES

Trimble Earthworks for compact machines is designed to deliver on the needs of your small machines.

Offering a wireless connection to the machine display for maximum flexibility, as well as compact machine-specific interface elements, Trimble's latest offerings will help you maximize the productivity of your small equipment.

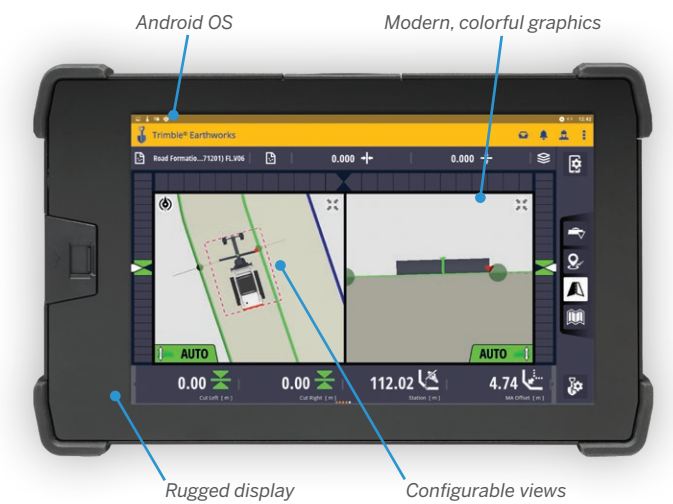

Trimble WorksManager Software



Trimble Earthworks: Compact Machine Configuration Options

Blade-Mounted Dual/Single GNSS System

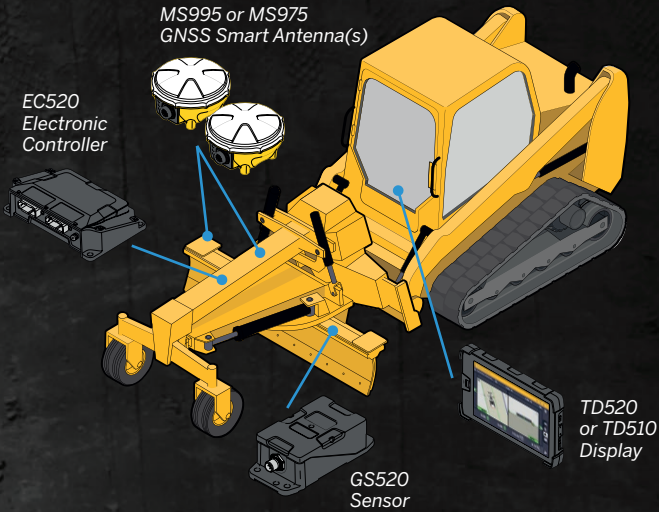

Dual/Single Laser System

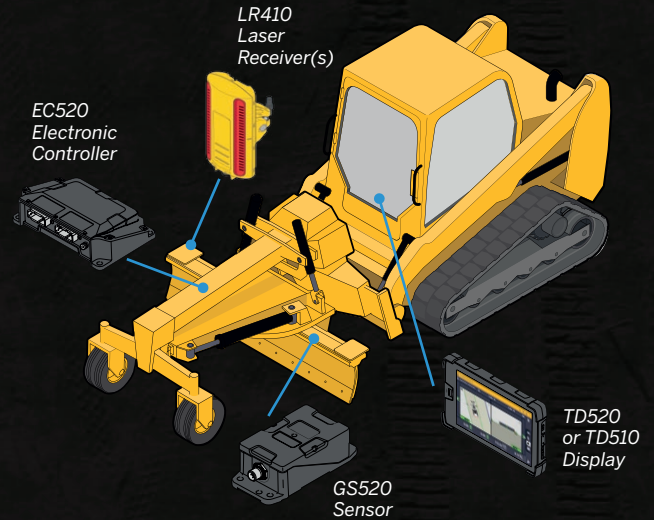

Universal Total Station System

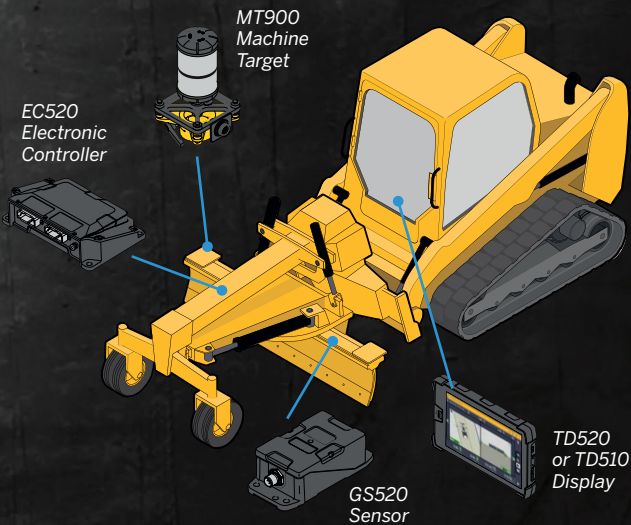

Dual/Single Sonic System

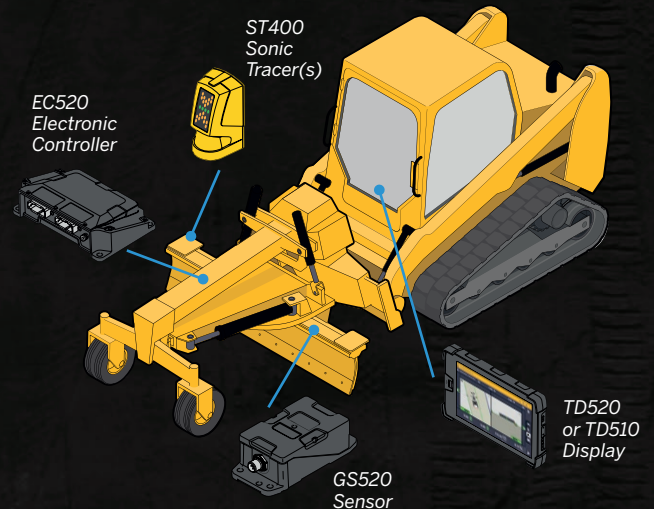

Trimble Civil Construction

10368 Westmoor Drive
Westminster, Colorado 80021 USA
800-361-1249 (Toll Free)
+1-937-245-5154 Phone
construction_news@trimble.com

heavyindustry.trimble.com/earthworks

© 2021, Trimble Inc. All rights reserved. Trimble and the Globe & Triangle, are trademarks of Trimble Inc., registered in the United States and other countries. PN 022482-4241B (11/21)